

Nazwa / Name
 Numer kodu / Code number

TN26/15/15-3E25
 4327 030 35541

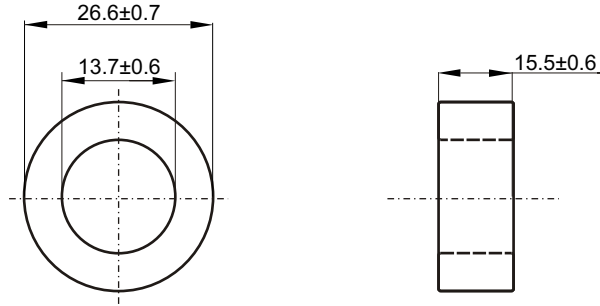

Magnetical dimensions according to: / Właściwości magnetyczne zgodne z: IEC 205

$\Sigma I/A$ (mm ⁻¹)	$\Sigma I/A^2$ (mm ⁻³)	A_e : 83.84 mm ²	l_e : 60.14 mm	V_e : 5042 mm ³
0.72	0.0086			
				Weight/Waga: ≈ 24 g

Specified value / Wartości specyfikowane

Symbol Symbol	Nominal Nominał	Tolerance Tolerancja	Unit Jednostka	Frequency Częstotliwość f [kHz]	Induction Indukcyjność [mT]	Equipment (Sprzęt pomiarowy) (1)	Temperature Temperatura t [°C]
Al	9600	±25%	nH	up to / do 200	≤0.1	HP-4284A	25±3

(1) Or similar / Lub podobny

VISUAL REQUIREMENTS according to: I-15-002
KONTROLA WIZUALNA według: I-15-002
High voltage insulation >2kV / Napięcie przebicia izolacji >2kV

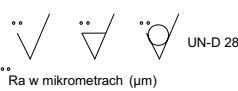
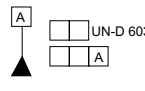
		Tolerances unless otherwise stated Tolerancja (jeśli nie ustalono inaczej) Dimensions Wymiary ±3% Angle Kąt				Name Nazwisko		Signature Podpis		Date Data			
General Roughness Chropowatość		Unit Jednostka mm.		MATERIAL 3E25 acc. to KPN-K7310 MATERIAL 3E25 zgodnie z: KPN-K7310		Check Sprawdził		Approval Zatwierdził		Other Inne			
Scale Skala Brak		PROJ.EURO PROJ.EURO		TN26/15/15-3E25 Toroid coated: Nylon White Toroid pokryty: Nylon biały		TYPE NUMBER / TYP			LAB REF No.				
Status/Status						4327 030 35540			---				
				D									
				C									
				B									
				A			09-01-29						
Issued by: Wydano przez: M.Zagórowska / K.S.				SUPERSEDES ZASTĘPUJE				SHEETS STRONY 1		SHEET STRONA 110-02			
K.S.		Property of WŁAŚCICIEL				Ferroxcube Polska Sp. z o.o. SKIERNIEWICE, POLAND				DATE DATA 09-01-29		A-4	