



Processing Specification MaxiBridge CSI

ERNI Electronics GmbH

Seestrasse 9 | 73099 Adelberg / Germany | +49 7166 50-0 | www.erni.com



Table of Contents

- 1. Fundamentals 3
- 2. Product characteristics 3
- 3. Description 4
- 4. Requirements 4
 - 4.1. Cable Construction 4
 - 4.2. Conductor crimp according to IEC 60352-2 5
 - 4.3. Insulations crimp 6
 - 4.4. Contact 6
 - 4.5. Form and position of the conductor in the crimping area 7
 - 4.6. Pull-out forces according to IEC 60352-2 respectively LV214 PG 10 8
 - 4.7. Tear-off characteristics 8
- 5. Tools 9
- 6. Crimp-Data 9
- 7. Assembly - single row version 10
- 8. Assembly - dual row version 11
- 9. Crimp contact replacement 12
- 10. Inspection 12
 - 10.1. Inspection of item characteristics 12
 - 10.2. Electrical Inspection 12
 - 10.3. PCB design 12
 - 10.4. Electrical test method 13
 - 10.5. Lifetime definition of pin header as adapter plug 13
- 11. Application note 14
 - 11.1. Recommendation for cable-laying 14

Change History

Change #	Change Description	Date (DE)
1	Crimp parameters 0,75 ²	11.10.2019
2	Article numbers of tooling for 0,75 ²	09.04.2019



1. Fundamentals

The acceptance criteria for cable and harness assemblies in the current IPC-A-620 manual is generally recommended for the assembly of ERNI connectors

2. Product characteristics

Crimp-Snap-In connectors of the MaxiBridge product family are available in various versions:

Number of pins single-row connectors

2, 3, 4, 5, 6, and 8-pin

Number of pins dual-row connectors ¹⁾

10 and 20-pin

Crimp contact sizes:

The crimp contacts are available in following sizes:

AWG 24/26, AWG 20²⁾/22 and AWG 18/20²⁾

¹⁾ Maximum diameter of the insulation for dual row connectors: 1,55 mm

²⁾ AWG 20 depending on the insulation diameter (see table 2)

3. Description

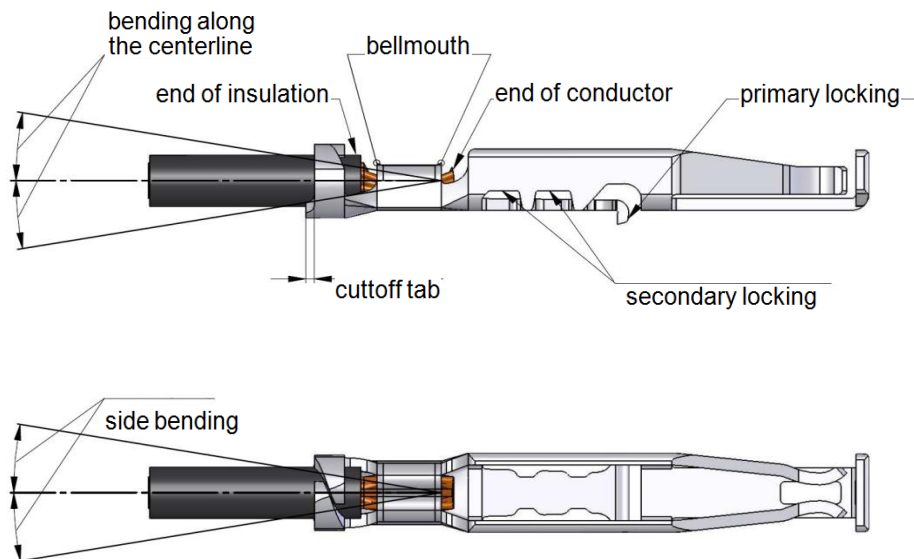

Figure 1

4. Requirements

4.1. Cable Construction

The cable construction for MaxiBridge crimp termination has to meet the requirements of IEC 60532-2.

Following cables are permissible under the scope of this standard:

- Stranded wires are to be used. Round solid core wires with a diameter of 0,25 mm to 3,6 mm are permitted, if their suitability has been tested.
- It is not permitted to solder/dip solder stranded conductors (strands) within the area intended for the crimp connection.
- After crimping, no further soldering should take place.
- Soft annealed copper with an elongation break of at least 10% is to be used.
- Uncoated or tin-plated (tin or tin-lead) or silver-plated single strands are to be used. The surface must be free from impurities or corrosion.
- Insulation must be easily removable from the cable without changing the physical properties of the conductor.

Possible insulation diameters can be taken from table 2.

In addition to IEC 60352-2, additional soldered crimp connections are possible for exceptional applications with special requirements. Crimp soldering must be securely preformed, so that alone the end of the conductor is soldered. The solder on the cable side must not extend past the wire crimp and join the wire strands. Ideally, the middle of the wire crimp must not be exceeded. To avoid the spring function being impaired, the primary locking tab on the contact side must not be wetted by solder.

4.2. Conductor crimp according to IEC 60352-2

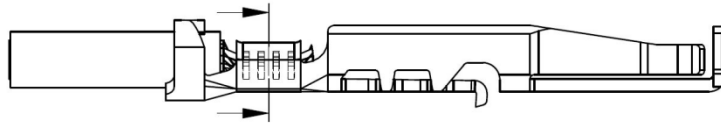

Figure 2

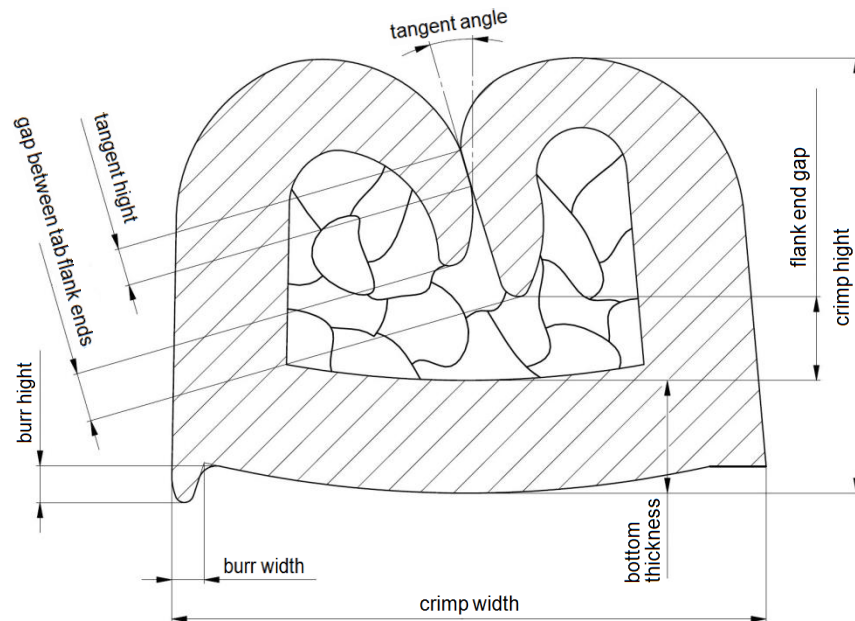

Figure 3

In addition to IEC 60352-2 the following specifications apply to MaxiBridge CSI:

Crimp height: Measured values and limits according to table 2

Crimp width: Measured values and limits according to table 2

Pull-out force: Measured values and limits according to table 2

Tangent angle: max. 30°

Tangent height: min. 0,5 x contact material thickness

Flank end gap: not permitted to touch the bottom

Gap between flank ends: max. 1,0 x contact material thickness

Burr height: max. 1,0 x contact material thickness

Burr width: max. 0,5 x contact material thickness

Bottom thickness: min. 0,75 x contact material thickness

Filling: Strands must be completely pressed in a honeycombed structure. Air pockets are not permitted.

4.3. Insulations crimp

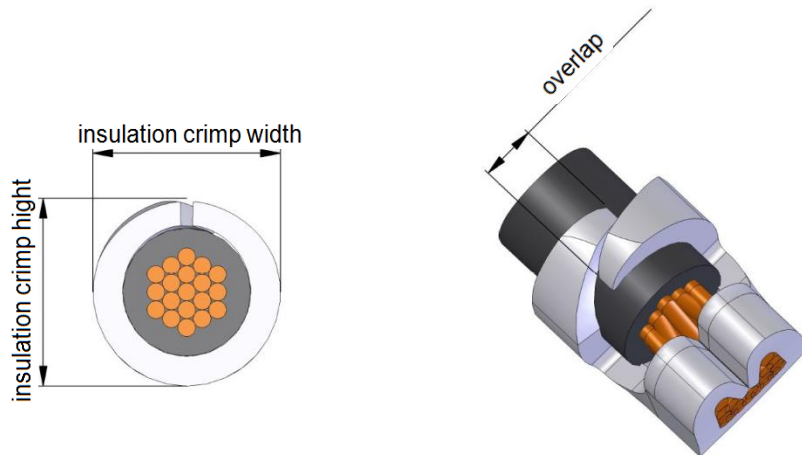

Figure 4

Insulation crimp height: Measured values and limits according to table 2

Insulation crimp width: Measured values and limits according to table 2

Overlap of the crimp flanks at entwine-crimp: min. 1.0 x contact material thickness.

Insulations crimping: Minor deformation of the insulation surface is allowed as long as the insulation crimp flanks do not cut, break, penetrate or puncture the wire insulation.

Ideally, the maximal deformation of 1/3 of the insulation thickness or the single contact material thickness should not be exceeded.

Stronger deformation, especially at soft insulation materials; is permitted as long as the insulation is not damaged by cutting, piercing and tearing.

Deviating from norm specifications, fully functional insulations crimp connections can be achieved without overlap of the crimp flanks. The prerequisite for doing so, is the achievement of the minimal pull-out force according to IEC 60352-2.

4.4. Contact

Locking tab deformation

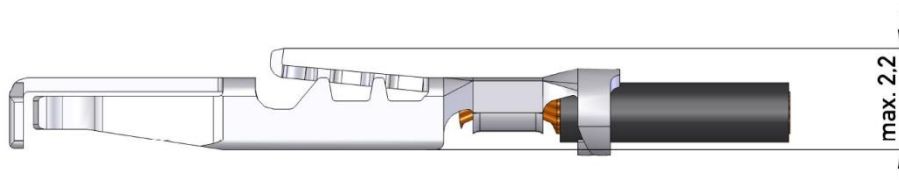

Figure 5

It is not permitted for the locking tab to be deformed inwards.

Deformation outward can reach a maximum of 2.2 mm.

The locking tab must not be impaired in terms of the function.

4.5. Form and position of the conductor in the crimping area

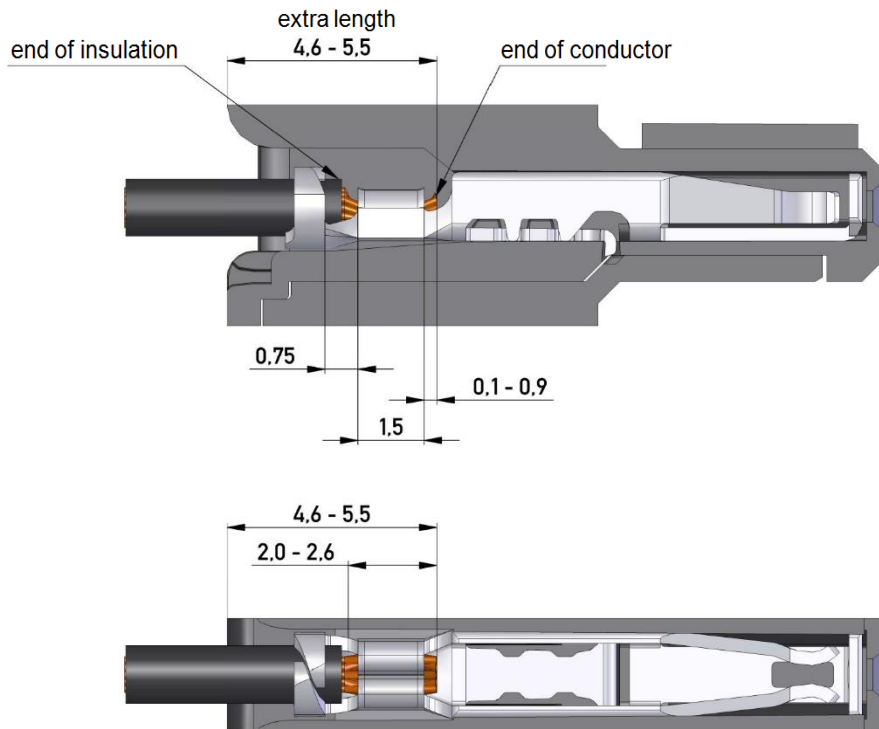

Figure 6

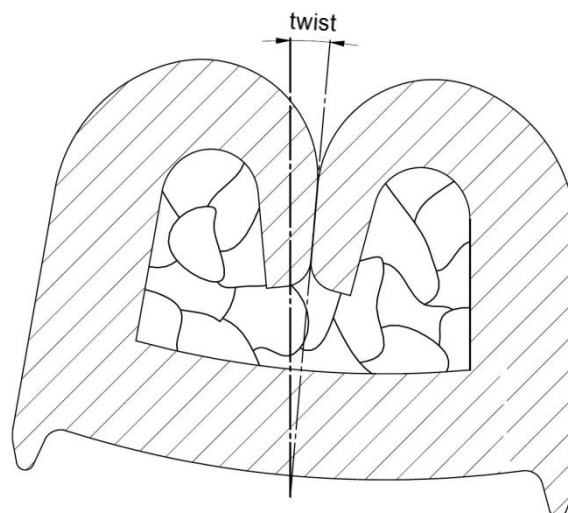

Figure 7

The suitable stripping length is $2,3 \pm 0,3$ mm.

The end of the conductor: 0,1 mm - 0,9 mm past the end of the conductor crimp area.

The conductor strands forming the brush are kept together as a group and not flared out.

The end of the insulation must be visible between the insulation crimp and the conductor crimp.

Ideally located in the middle.

Bellmouth on the cable side must be recognizable. Bellmouth on the side of the conductor end is permitted.

Side bending may not exceed 3°.

Bending along the centerline may not exceed 5° (see figure 1).

Twist may not exceed 5° (see figure 1).

The bellmouth must not exceed 0,3 mm (see figure 1).

4.6. Pull-out forces according to IEC 60352-2 respectively LV214 PG 10

Minimum pull-out forces are listed in table 2.

4.7. Tear-off characteristics

The tear-off characteristics have to be assessed positively, if the single strands tear-off irregularly behind the bellmouth once the pull-out force (see table 2) has been achieved.

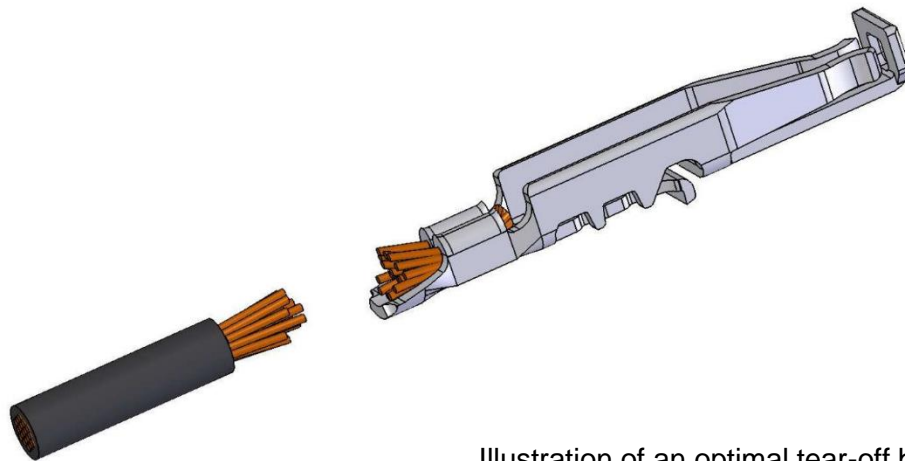

Illustration of an optimal tear-off behavior

Figure 8

The single strands tear-off directly behind the bellmouth: overpressed.

The single strands do not tear-off and are pulled out of the crimp: underpressed.



5. Tools

Id No. crimp contacts		Conductor cross section	Insulation- Ø [mm]	Description	Crimp tool with mechanical feed	Wearing parts kit for crimp tool with mechanical feed	Hand crimping tool
10.000 pcs	500 pcs						
464771	464772	AWG 18	1,45 - 1,90	ERNI MaxiBridge AWG 18/20	817478	817473	992215
464771	464772	0,75 mm ²	1,45 - 1,90	ERNI MaxiBridge AWG 18/20	041522	362939	-
464771	464772	AWG 20	1,45 - 1,90	ERNI MaxiBridge AWG 18/20	817478	817473	-
464762	464763	AWG 20	1,20 -1,55	ERNI MaxiBridge AWG 20/22	817479	817475	952050
464762	464763	0,50 mm ²	1,20 -1,55	ERNI MaxiBridge AWG 20/22	817479	817475	-
464762	464763	AWG 22	1,20 -1,55	ERNI MaxiBridge AWG 20/22	817479	817475	952050
464762	464763	0,35 mm ²	1,20 -1,55	ERNI MaxiBridge AWG 20/22	817479	817475	-
464765	464766	AWG 24	0,90 -1,15	ERNI MaxiBridge AWG 24/26	817480	817477	992216
464765	464766	AWG 26	0,90 -1,15	ERNI MaxiBridge AWG 24/26	817480	817477	992216

Table 1

6. Crimp-Data

Id No. crimp contacts		Conductor cross section	Insulation- Ø [mm]	Description	Conductor crimp nominal value		Insulation crimp recommended reference value ¹⁾		Pull-out force [N]
10.000 pcs	500 pcs				height [mm]	width [mm]	height [mm]	width [mm]	
464771	464772	AWG 18	1,45 - 1,90	ERNI MaxiBridge AWG 18/20	1,35±0,05	1,90±0,05	Iso-Ø +0,45 ±0,05	2,05±0,1	90 ³⁾
464771	464772	0,75 mm ²	1,45 - 1,90	ERNI MaxiBridge AWG 18/20	1,10±0,05	1,90±0,05	Iso-Ø +0,45 ±0,05	2,05±0,1	85
464771	464772	AWG 20	1,45 - 1,90	ERNI MaxiBridge AWG 18/20	1,13±0,03	1,90±0,05	Iso-Ø +0,45 ±0,05	2,05±0,1	60 ³⁾
464762	464763	AWG 20	1,20 -1,55	ERNI MaxiBridge AWG 20/22	1,13±0,03	1,63±0,05	Iso-Ø +0,45 ±0,05	1,90±0,1	60 ³⁾
464762	464763	0,50 mm ²	1,20 -1,55	ERNI MaxiBridge AWG 20/22	0,92±0,03 ²⁾	1,63±0,05	Iso-Ø +0,45 ±0,05	1,90±0,1	60 ²⁾
464762	464763	AWG 22	1,20 -1,55	ERNI MaxiBridge AWG 20/22	0,98±0,03	1,63±0,05	Iso-Ø +0,45 ±0,05	1,90±0,1	40 ³⁾
464762	464763	0,35 mm ²	1,20 -1,55	ERNI MaxiBridge AWG 20/22	0,92±0,03 ²⁾	1,63±0,05	Iso-Ø +0,45 ±0,05	1,90±0,1	50 ²⁾
464765	464766	AWG 24	0,90 -1,15	ERNI MaxiBridge AWG 24/26	0,93±0,03	1,45±0,05	Iso-Ø +0,45 ±0,05	1,50±0,1	28 ³⁾
464765	464766	AWG 26	0,90 -1,15	ERNI MaxiBridge AWG 24/26	0,78±0,03	1,45±0,05	Iso-Ø +0,45 ±0,05	1,50±0,1	15 ³⁾

Table 2

¹⁾ At low insulation hardness, the suitable insulation crimp-height can be smaller as long as the requirements respectively criteria for insulation crimp remain maintained

²⁾ According to LV214 PG 10 / Slow-Motion Test, Edition 2010-04

³⁾ According to IEC 60352-2

7. Assembly - single row version

The single row MaxiBridge connector consists of housing with contact chambers and locking component (secondary locking). When handling, please take note that housing and locking are not unintentionally locked before all the contacts have been assembled.

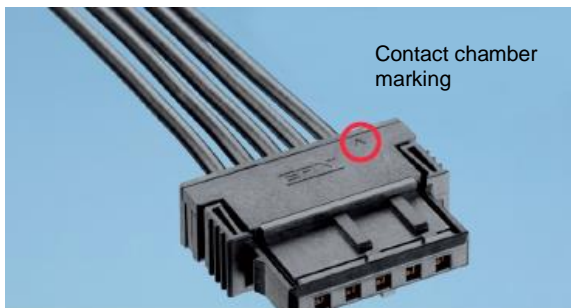
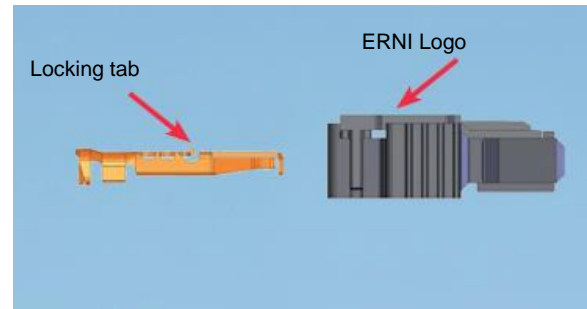
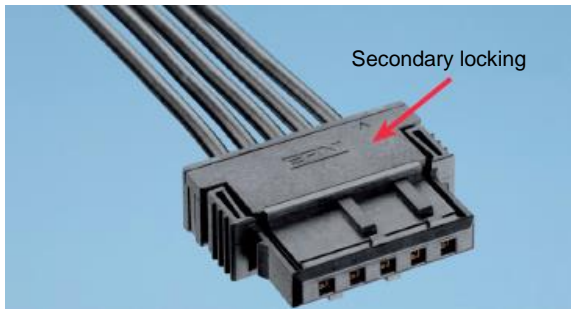

Contact chamber assignment is taking place in accordance with the work documents. The contact must be inserted in correct position into the chamber until the primary locking is audibly engaged.

Correct engagement of the primary locking can be checked by pulling backwards the cable (max. 10N).

After contact assembly, the housing and secondary locking must be gently pressed together. The secondary locking must be fully engaged and closed.

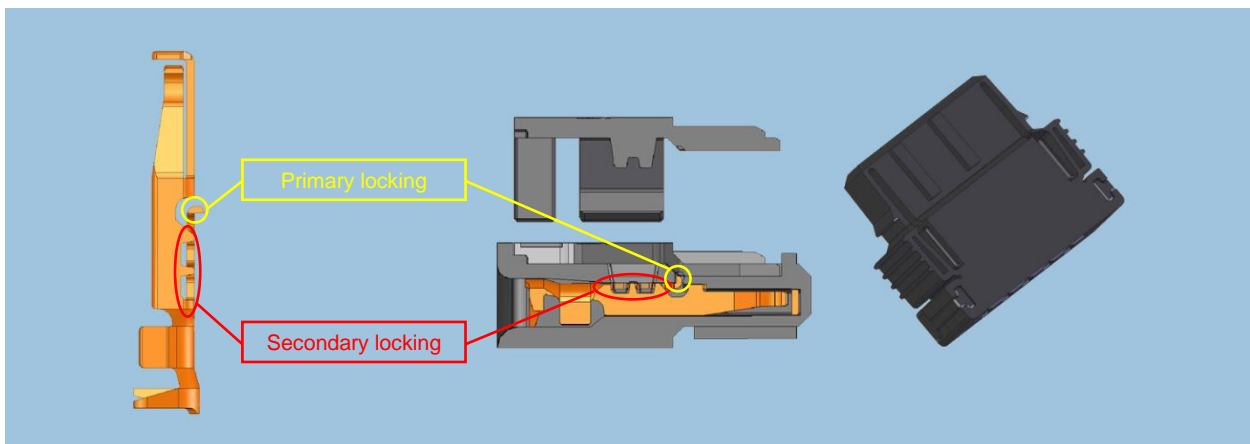

Only fully engaged locking ensures proper secondary locking function.

8. Assembly - dual row version

The dual row MaxiBridge connector consists of housing with contact chambers and two locking components (secondary locking left and right).

When handling, please take note that housing and locking are not unintentionally locked before all the contacts have been assembled.

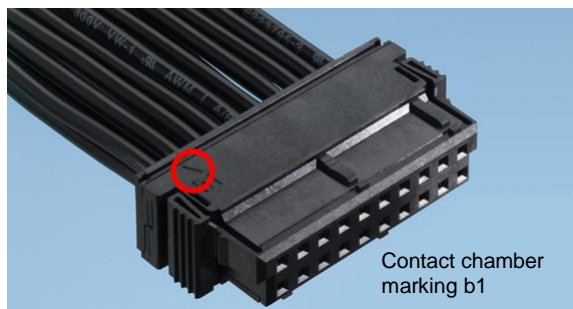
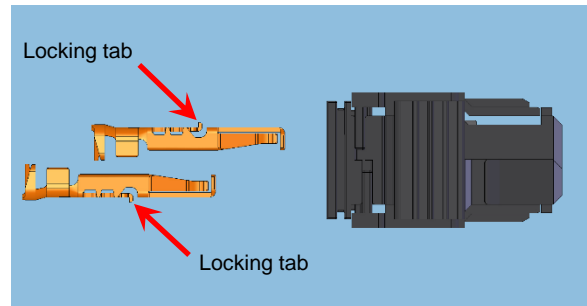
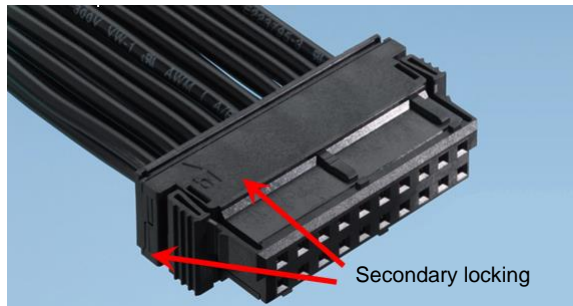

Contact chamber assignment is taking place in accordance with the work documents. The contact must be inserted in correct position into the chamber until the primary locking is audibly engaged.

Correct engagement of the primary locking can be checked by pulling backwards the cable (max. 10N).

After contact assembly, the housing and secondary lockings must be gently pressed together. The secondary lockings must be fully engaged and closed.

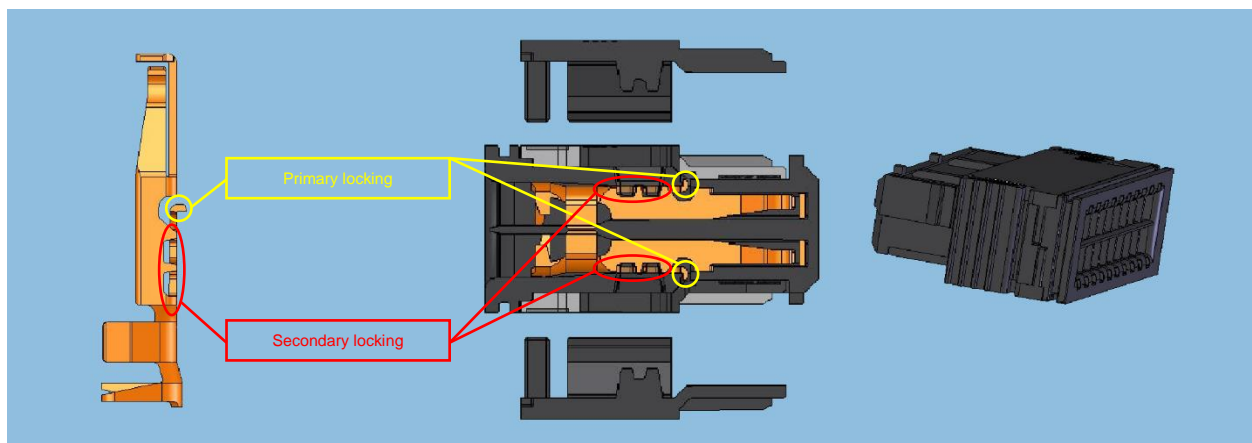

Only fully engaged lockings ensure proper secondary locking function.

9. Crimp contact replacement

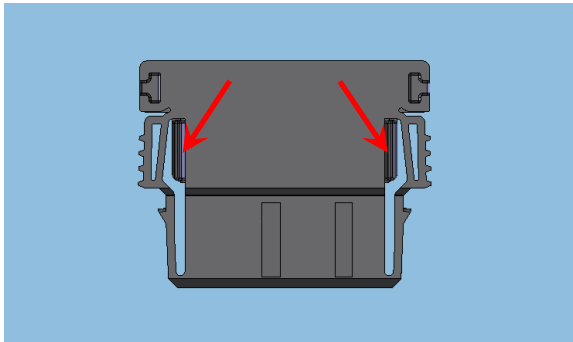

Single row MaxiBridge connector

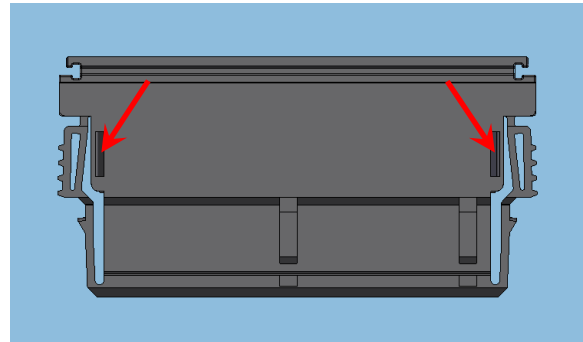

Dual row MaxiBridge connector

The interlock component (secondary locking) must be completely removed when replacing or removing a crimp contact already locked into the connector housing.

The single row connector has one, the dual row connector has two secondary interlocks. Regardless if the locking is pre-engaged (delivery state) or already fully locked, by means of ERNI tool No. 464790 the two locking hooks can be depressed.

The locking can then be removed. An unlocked secondary locking must not be reused but instead replaced by a new one.

Push down the locking tab (primary locking) using either ERNI tool No. 464790 or a small screwdriver and remove the contact by pulling backwards the cable.

The detached crimp contact can be reused however, must be checked for possible damage, especially deformation of the primary locking tab and if necessary replaced.

10. Inspection

10.1. Inspection of item characteristics

The requirements for wire and insulation crimp are to be ensured by suitable variable and attributive tests.

This includes tear-off test, evaluation of the microsection as well as the deviations from the specified form and shape.

10.2. Electrical Inspection

For the inspection of the MaxiBridge cable assemblies the inspected female connector needs to be electrically contacted with the pin headers. To inspect all contacts against one another, the pin headers need to be connected on a printed circuit board.

10.3. PCB design

If MaxiBridge connectors with several number of pins need to be inspected, it is recommended to mount an appropriate quantity of adapter pins on the PCB. Depending on the PCS size it is also recommendable to place multiple headers with the same number of pins.

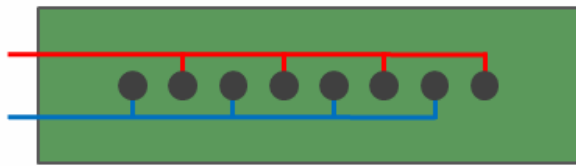

PCB Layout for single row connectors

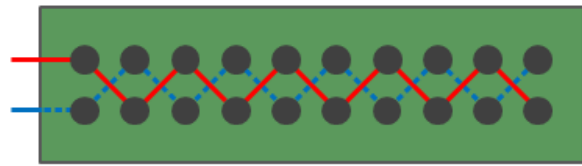

PCB Layout for dual row connectors

10.4. Electrical test method

Extra low voltage test < 42 V without protection against contact

This test method requires at least voltage of ≥ 20 V (AC or DC). The test current is irrelevant, however it should not be so high as to burn away short circuits at the first current flow caused by very small metal chips. Using this test method it is recommended to indicate the test results (short circuit) by acoustic or visual signals. This can be realized by using light bulb, LED or audible alarm (buzzer). The current indicating such signals is sufficient enough to detect a low-resistance short circuit without the risk of burning away the bridging caused by fine metal chips. Alternatively, a current measurement device can be used as a display unit which shows the current flow in case of failure. For the reasons indicated above, the test current of the alternative method should be limited to max. 100 mA.

The function of the test equipment and the adapter plug should be tested regularly using outturn samples which have defined short circuits.

This test method is used to determine low-resistance short circuits.

10.5. Lifetime definition of pin header as adapter plug

By using pin headers as an adapter should be ensured, that the contact surface meets the requirements of performance class 1 for a lifetime of 500 mating cycles. Will the adapter plug be used without long resting phases it is possible to perform significantly more mating cycles than in regular use in an assembly.

Due to the recurring mating no corrosion spots can be built up. However, cleaning of the adapter at regular intervals is urgently required because of possible contact surface damage by abrasion particles.

The end of life is reached when the plating is worn through up to the base material at any point of the contact.

11. Application note

11.1. Recommendation for cable-laying

For cable-laying direct behind the contact end (with regards to the cutoff-tab) the bending radius shall not be less than triple¹⁾ cable diameter-size. This avoids the impairment of the insulation support at the insulation-crimp.

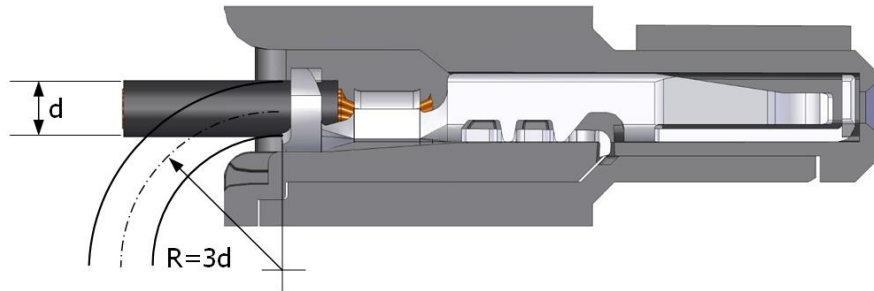

¹⁾ Based on bending radii for flexible cables according to DIN VDE 0298 Part 3